



Körting Hannover AG

RECOMMENDATIONS
for
SOUND INSULATION
OF
JET EJECTORS



Körting Hannover AG
Bereich S
Postf. 911363, D-30433
Hannover
Tel. (0511) 2129-0 Fax -223

**RECOMMENDATIONS
FOR SOUND INSULATION
OF
JET EJECTORS**

*Technisches Datenblatt
Techn. Data Sheet*

109090 468250e

Seite/Page 1 von/of 5

General

The procedures described below concerning insulation of jet ejectors, condensers, silencers and pipe lines should be considered as recommendations. By means of such insulation measures, a reduction of the solid-borne sound radiation by approx. 20 dB(A) can be obtained. The connected piping has to be insulated together with the ejector.

If certain sound pressure levels should be guaranteed, the thicknesses of insulation must be calculated individually.

Sound Insulation Measures - Construction of the Sound Insulations

The various kinds of material listed below may be used for all sound insulations on jet ejectors, condensers, pipe lines and silencers.

For damping material mineral wool formed as plates and/or shells having a maximum density of 140 kg/m^3 (in mounted condition) should be used. The thickness of the damping layer of mineral wool are to be covered by galvanized steel sheets having a thickness of $< 1,5 \text{ mm}$. The inside of the sheet-metal jacket is to be provided with a viscoelastic layer of 3 mm thickness. This viscoelastic damping material should have the following physical properties:

Density $> 1000 \text{ kg/m}^3$

Product of loss factor and elastic modulus
 $> 10^9 \text{ N/m}^2$ in the temperature range between 0°C and 60°C .

It must be ensured that the connection between the viscoelastic damping layer and sheet-metal jacket is permanent.

Attention must be paid to the application of the sound insulation on jet ejectors, condensers, pipe bends and blowoff-silencers that no rigid connections between the outside sheet-metal jacket and the walls of piping or vessel respectively occur. We would especially point out that no inelastic spacers should be used. Examples for constructions are shown in figures 1 to 3.

Flanges and fittings are also to be provided with a sound insulation. Examples for constructions are given in figure 4 and 5.



Körting Hannover AG
Bereich S
Postf. 911363, D-30433
Hannover
Tel. (0511) 2129-0 Fax -223

RECOMMENDATIONS FOR SOUND INSULATION OF JET EJECTORS

Technisches Datenblatt
Techn. Data Sheet

109090 468250e

Seite/Page 2 von/of 5

Fig.1-T-Junction of pipes

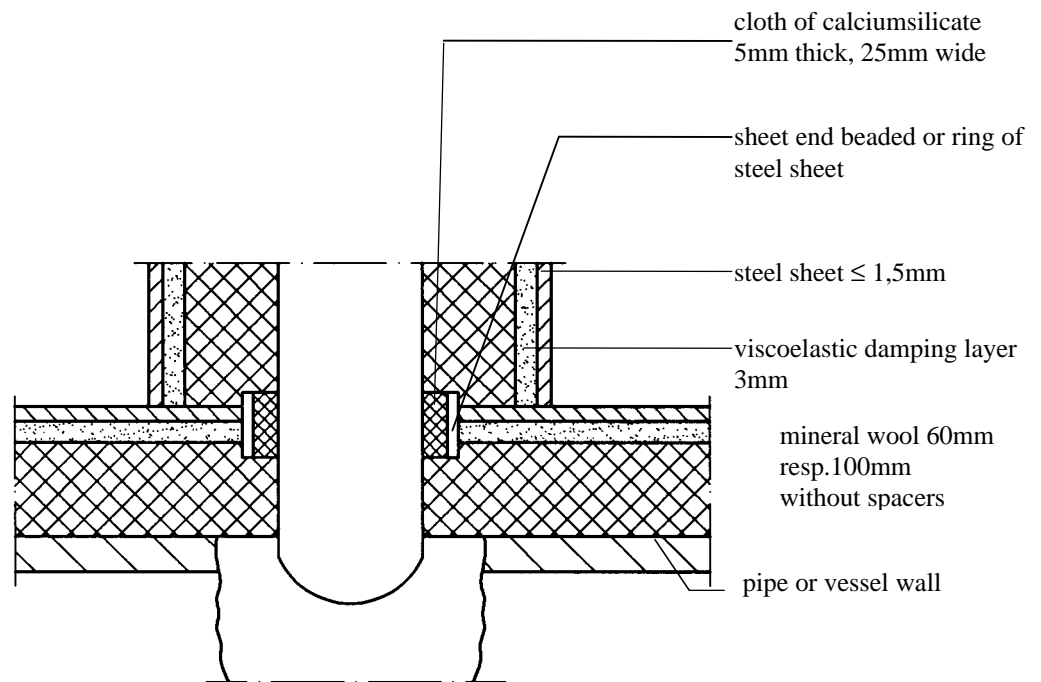
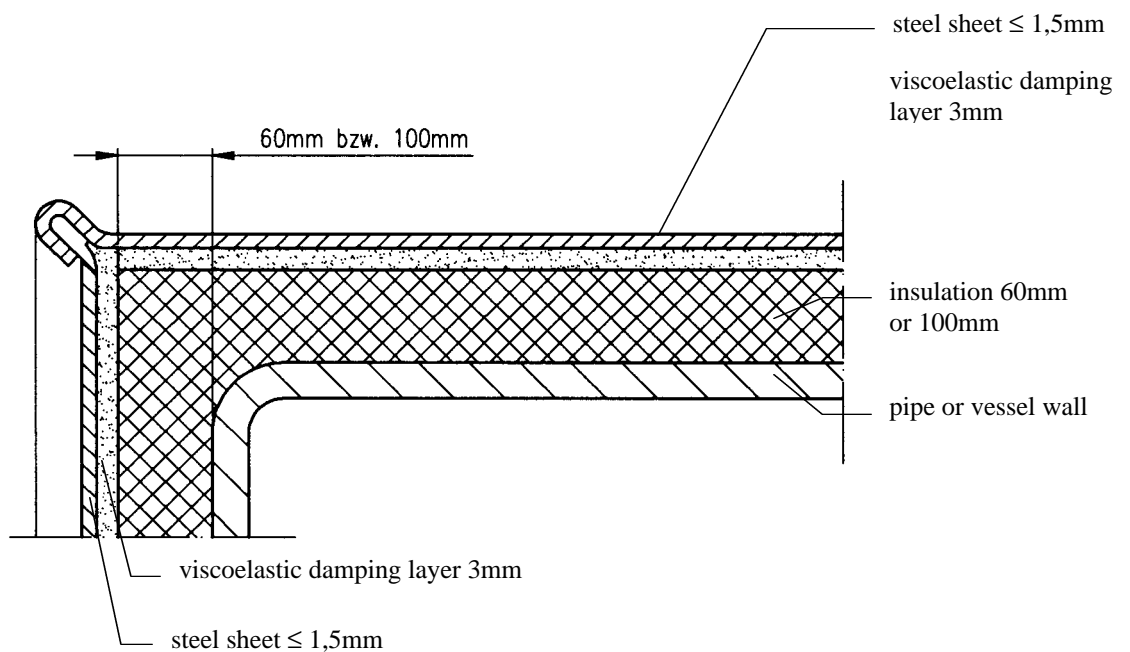

Fig.2- End of acoustical lagging





Körting Hannover AG
Bereich S
Postf. 911363, D-30433
Hannover
Tel. (0511) 2129-0 Fax -223

**RECOMMENDATIONS
FOR SOUND INSULATION
OF
JET EJECTORS**

*Technisches Datenblatt
Techn. Data Sheet*

109090 468250e

Seite/Page 3 von/of 5

Fig. 3-Acoustical lagging with continuing pipe- or vessel wall

(with closing piece)

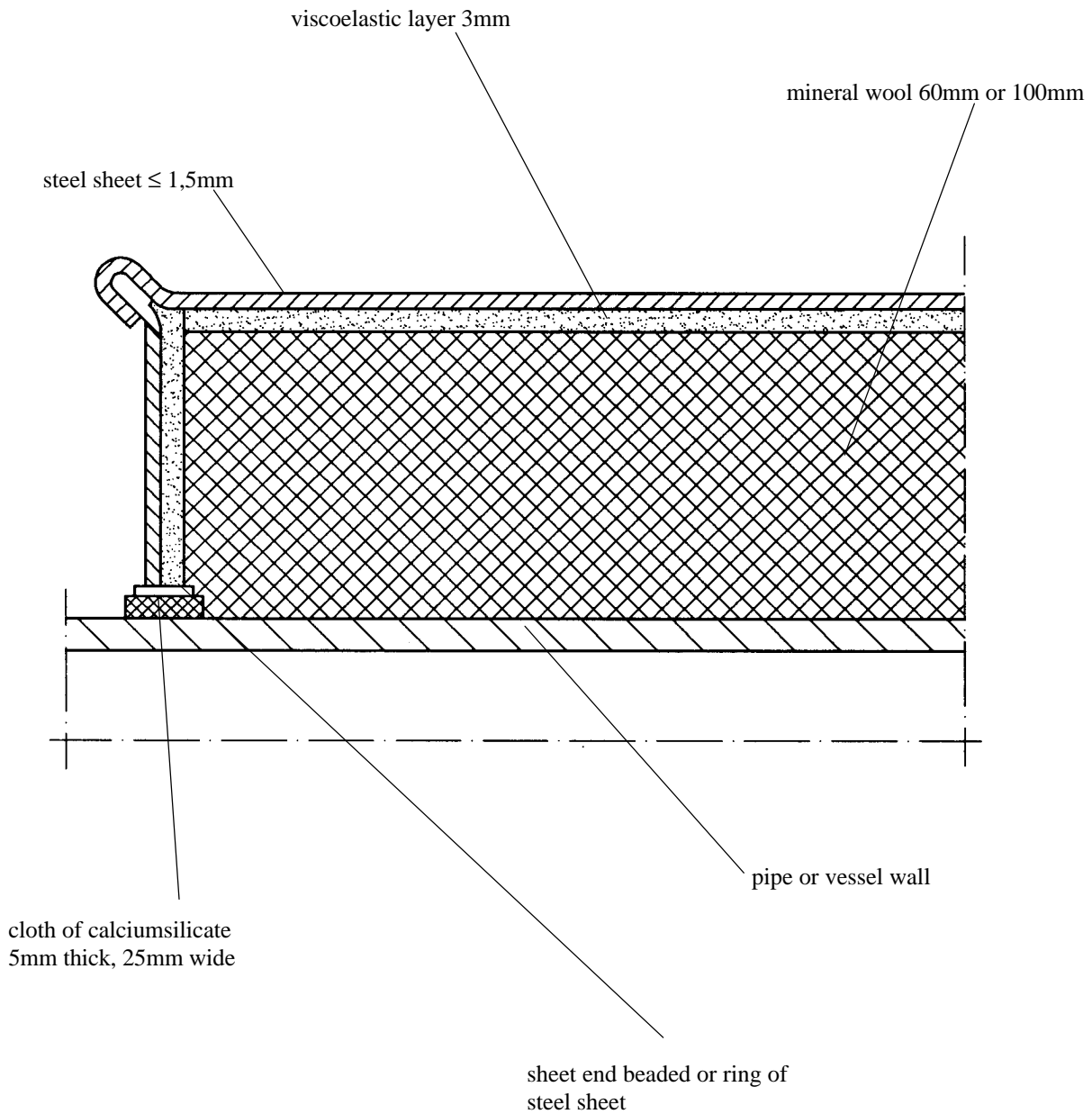



Körting Hannover AG
Bereich S
Postf. 911363, D-30433
Hannover
Tel. (0511) 2129-0 Fax -223

RECOMMENDATIONS FOR SOUND INSULATION OF JET EJECTORS

Technisches Datenblatt
Techn. Data Sheet

109090 468250e

Seite/Page 4 von/of 5

Fig.4-Lagging of a flange

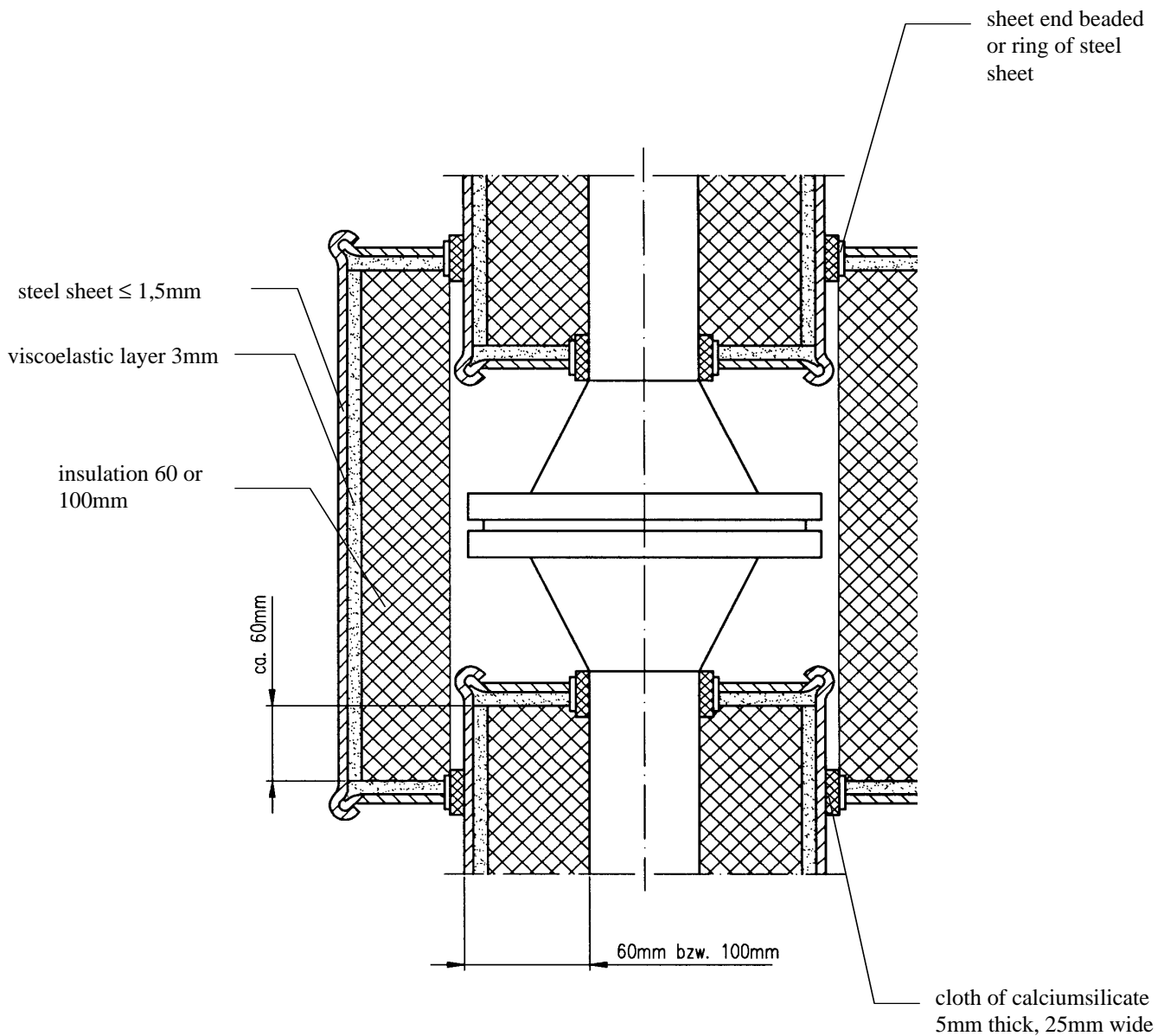



Körting Hannover AG
Bereich S
Postf. 911363, D-30433
Hannover
Tel. (0511) 2129-0 Fax -223

RECOMMENDATIONS FOR SOUND INSULATION OF JET EJECTORS

Technisches Datenblatt
Techn. Data Sheet

109090 468250e

Seite/Page 5 von/of 5

Fig.5-Lagging of a valve

