



# Troubleshooting and performance checks

**Körting**

THE EJECTOR COMPANY

Steam jet vacuum ejectors  
and vacuum systems

Körting Academy

# Troubleshooting and performance checks

Steam jet vacuum ejectors rarely underperform if operated under the conditions they were designed for. Our instructions already list possible malfunctions and problems if the ejector doesn't perform as expected because it has been incorrectly installed.

The explanations and information in the guidelines also apply to a drop in performance that may occur gradually or suddenly after a longer period of operation.

Wear and tear or dirt are typical causes of the ejectors underperforming. To identify faults more quickly and minimise the time spent troubleshooting, we recommend proceeding as follows – depending on the type of malfunction.

After inspecting the equipment from the outside and establishing the ejectors' typical temperature

areas, examine the vacuum system step by step and conduct a performance check. An inspection from the inside, which would require dismantling the equipment, is only required in exceptional cases.

The purpose of performance measurements on steam jet vacuum ejectors or units containing them is to verify performance (suction pressure, suction flow, start-up time) and consumption (motive steam, cooling water).

Performance measurements can be carried out on the test rig (recommended) or on site. These are used to check and guarantee the technical data is correct and monitor ejectors that are running or on which maintenance has been carried out. The information provided here focuses on establishing the suction pressure and the suction flow on site in the event of a problem.



We have also provided a brief performance measurement guide so that a performance measurement can be carried out quickly and easily should problems occur. A full outline with all options for conducting trials and the rules for measuring temperatures, pressures and mass flows can be found in DIN 28430: Rules for the measurement of steam jet vacuum pumps and steam jet compressors and in publications by the Heat Exchange Institute (HEI, New York).

# Action and recommended sequence when troubleshooting

If a multi-stage steam jet vacuum ejector's performance gradually or suddenly decreases after it has been running for a long period of time, external influences or changes inside the pump could be the causes.

If it's not possible to pinpoint the cause, troubleshooting always starts at the last stage when steam is being conveyed to the atmosphere. Only if this stage delivers the intended pre-vacuum can the pre-stage also work with

the discharge pressure intended for it.

**The stages are counted in the direction of atmospheric pressure.**

The first stage is connected to the process unit requiring evacuation or to a condenser. In order to systemise troubleshooting, two types of pumps should be taken into account (see figure):

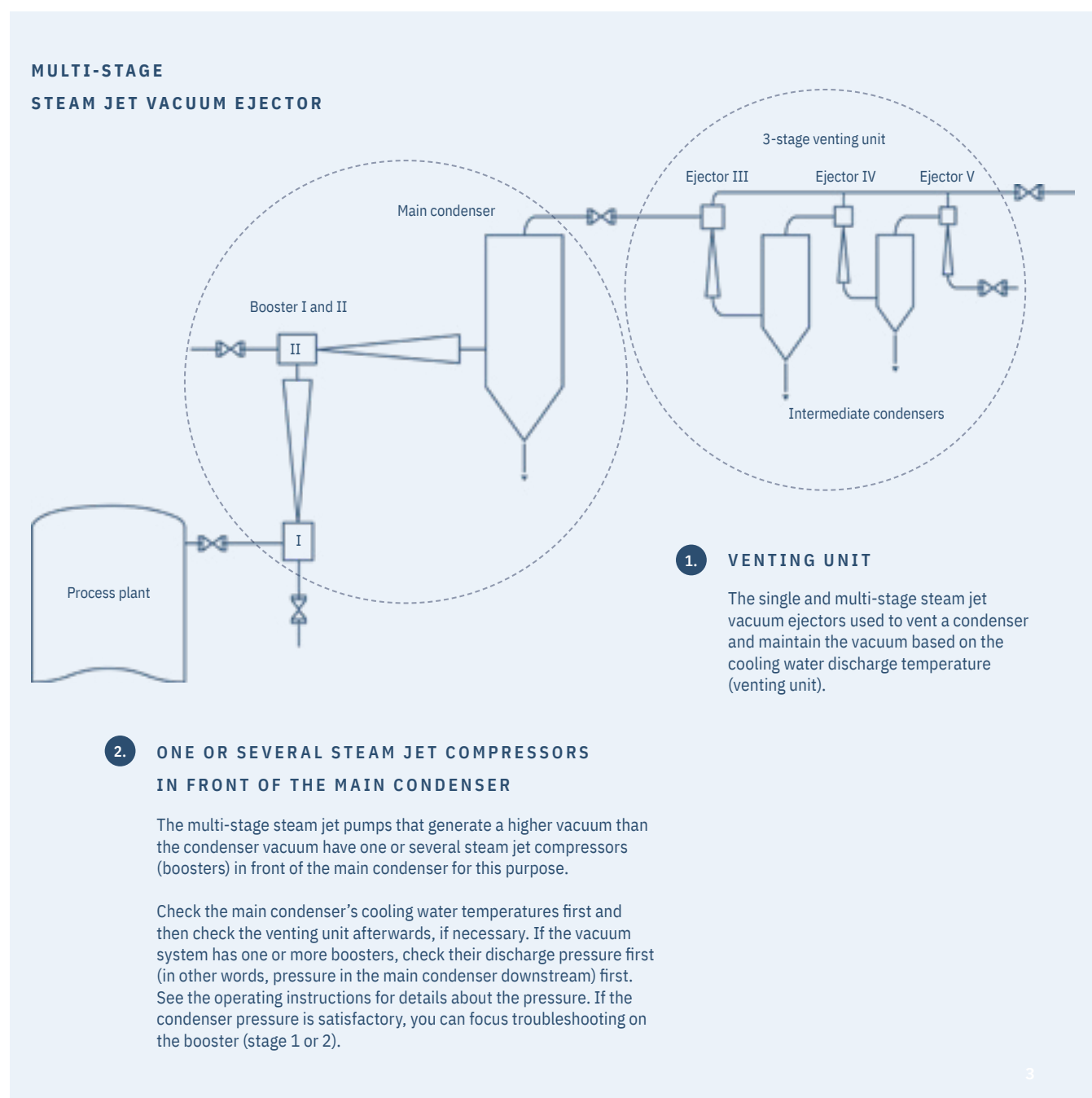

# Sudden loss of vacuum

If there's a sudden loss of vacuum, check the measuring instruments first (and calibrate if necessary) to see if a drop in performance really has occurred. Make sure there are no clogged or brittle measurement pipes in the measuring instruments and pockets of water that might be producing incorrect readings. Compare the measurement results with the information in the operating instructions. The cooling water outlet temperatures specified must not be exceeded under any circumstances because the discharge pressure for the steam jet pumps will otherwise be too high.

> Continue troubleshooting if the measuring instruments are working properly.

If the venting unit can be disconnected from the main condenser (via a shut-off valve or blind flange),

> Carry out a zero-load test.

If half the condenser pressure isn't reached, the fault must already lie in the venting unit, or in front of the main condenser.

Körting steam jet compressor at the Hanover plant



## SUSPECTED CAUSE – COOLING WATER

**1.** Touch all the inlet and outlet pipes on the condensers to establish if there are any differences in temperature. Compare the differences with the operating instructions. If you can't detect any differences in temperature in any of the mixing condensers (everything is equally hot), the nozzle in the mixing condenser may be partially or completely clogged.

> Remove and clean the nozzle.  
Check the spray angle.

**2.** If water escapes from the atmospheric steam jet ejector, the previous intermediate condenser is full of water. Tap it to establish whether it sounds hollow or full.

Check the tail pipes' outlet in the seal tank to ensure it isn't blocked. If it's a barometric type, check that the drop height is also as required. It can change slightly due to the atmospheric pressure or significantly if the specific weight is changed due to a high proportion of gas in the water.

> Check there are no rust or leaks in the tail pipes.

Leaks in the tail pipes cause air to enter and can block the outflow.

A significant number of bubbles forming in the seal tank indicates too much air or gas, which may already be coming from the process unit.

**3.** Where surface condensers have tail pipes, the condensate should also be able to drain easily into a seal tank. If there are condensate loops, exam-

ine these to see whether they are blocked and the intermediate condenser is full of condensate.

In the case of condensate pipes behind condensate pots, you can feel them opening regularly if they are operating properly.

> Tap the cooler, which should sound empty.

If pumps drain the surface condensers, check these and their gland packings. Gland packings must have a separate water supply.

**4.** Now check whether the seal tank has enough buffer volume (particularly when starting to fill the tail pipes) or whether sludge etc is causing problems.

> Then clean it.

**5.** Then check whether the water pressure in front of the condenser is constant. Has there been a change in the cooling water supply in the meantime or are any other devices connected to the pipe? Also check whether air is being suctioned in through the cooling water pump's suction nozzle. This can occur if the cooling water is being suctioned in by the vacuum.

> Watch out for any swirls forming at the point where the water is suctioned in and any bubbles forming in the seal tank.

**6.** Cooling water discharge temperatures must not be exceeded.

> Compare the figures shown with the operating instructions.

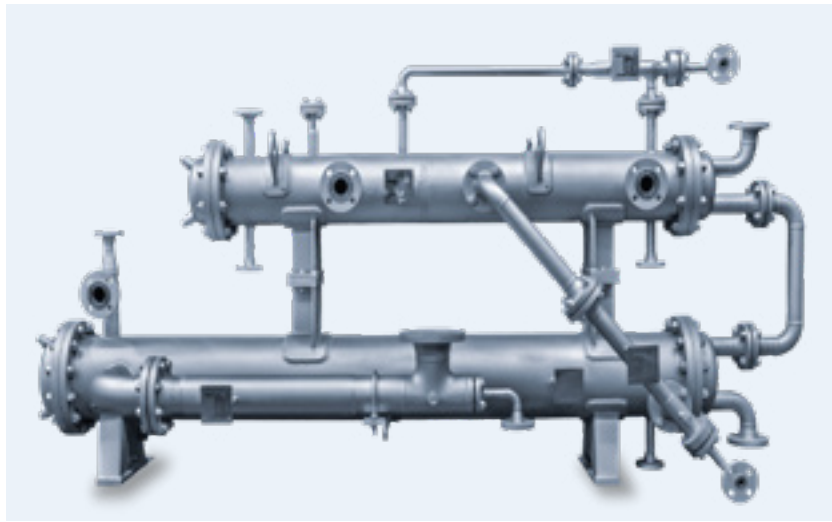

Three-stage steam jet vacuum system

## SUSPECTED CAUSE – MOTIVE STEAM

1. Open all bleed points on the motive steam pipe to check the steam quality. Wet steam will be ejected with a white plume. Let the steam blow out until the plume disappears and the steam flow is constant.
2. Check the motive steam pressure in front of the nozzle. If indicating pressure gauges are used, remember that when the motive steam is turned off, the vacuum still present in the system can also act on the pressure gauge (fitted between the pressure valve and jet ejector) and cause the pointer to give a false reading of up to 1 bar. The actual motive steam pressure in front of the nozzle would then effectively be 1 bar lower.
  - In this case, use a vacuum gauge or remove the stop pin. Check strainers, siphons and long measurement pipes.
3. Check the intermediate condensers and jet ejectors. If an intermediate condenser is at a lower temperature than specified in the operating instructions and there are no hot areas at the steam inlet and cooling water outlet, this indicates the motive nozzle on the upstream jet ejector is blocked.

➤ Inspect the motive nozzle.

During compression, the jet ejectors adopt the temperatures corresponding to the pressure ranges - if they are suctioning in air or steam that is not superheated. Normally, suction nozzles and

mixing nozzle (diffusor inlet) should therefore be colder than the diffusor outlet. At absolute pressures below 6 mbar, frost or even ice will also build up on the outside of an unheated diffusor.

4. It's easy to check whether the motive steam nozzle is blocked because the nozzle can be easily removed with the steam chamber or manifold. Hold the nozzle so that dirt or foreign bodies don't fall out when you're checking it.
  - Carefully remove foreign bodies without damaging the nozzle hole. Find out the source of the foreign bodies to stop the same thing happening again.
  - In the case of small jet ejectors, subject the diffusor to a visual inspection as well.
  - Once you've established the motive nozzles are blocked, blow out the motive steam pipe too.
5. When loosening or unscrewing the motive steam nozzles from the steam chamber or manifold, do not forget the gasket. Any misdirected motive steam would reduce suction capacity accordingly.

After cleaning the nozzles, check whether their holes comply with the diameters in our operating instructions. Twist drills calibrated to tenths of a millimetre can be used as a plug gauge if necessary.

## SUSPECTED CAUSE – LEAKS

The steam jet vacuum ejector's suction capacity is based on the maximum quantity of expected air leakage from the process unit. After the ejector has been running for a long time, additional air leakage can lead to a gradual or sudden drop in vacuum.

Possible causes:

- Torn gaskets
- Gland packings on valves and condensate pumps whose packing has become dry and leaky. Seal water for condensate pumps should come from a separate water supply.
- Corroded tail pipes.
- Erosion of the elbow behind a jet ejector when motive steam is wet.
- Thread erosion. If threaded motive nozzles are used, they can loosen and steam can also flow into the jet ejector through this connection.
- Punctures on the condenser on the surface where the cooling water hits (spray coming off the water nozzles) and on the surface where the steam hits (only if a jet ejector is horizontal).

> Carry out a leakage test to check.



# Slow but steady loss of vacuum after a prolonged period of operation

While a sudden loss of vacuum is usually caused by one single fault, a slow drop after a long period in operation indicates the start of wear and tear in the venting unit and particularly in the last stage.

> It is then high time to replace the nozzles.

1. Check the measuring instruments to start with to ensure that the display is correct. Brittle measurement pipes can also cause an incorrect result to be shown.

After a long period in operation, the last stage (towards the atmosphere) may be eroded or the outlet pipe may be dirty and encrusted with deposits.

- > Measure the intermediate vacuum on the measuring sleeve of the upstream and compare the figures with the operating instructions.
- > Remove and clean the outlet pipe of the last ejector stage. Blow out the last stage and remeasure the intermediate vacuum.
- > If they are still not working properly, carry out an internal inspection of this steam jet ejector and check the diameter of the motive nozzle and diffusor.
- > If encrusted with deposits, clean it. If torn; fit replacement nozzles (ensuring the gaskets are in a perfect condition. Rebore as an emergency solution, but only after consulting Körting).



Körting three-stage steam jet vacuum system with surface condenser

2. If the intermediate condensers are surface condensers, the condenser tubes might be dirty and even encrusted with deposits both inside and outside. The required intermediate vacuum will then no longer be achieved. Should this be the case:

> Inspect and clean it.

3. Leaks might also be occurring here.

> Check gland packings and inspect for leaks.

4. If inspecting and touching them gives no indication of where the fault is coming from:

> Fit measuring instruments at each stage in order to compare the intermediate vacuums with the specifications in the operating instructions.

> Isolate the steam jet vacuum ejector from the process unit and carry out a performance check.

5. Leaky motive nozzle feeds could also be causing problems. This causes motive steam to flow into the suction chamber.

> Replace gaskets.

# Fluctuating vacuum

There could be several reasons inside or outside the system for a fluctuating vacuum.

1. The required vacuum is achieved. However, is the final jet ejector pulsating while running and emitting whistling sounds? Adding steam to its suction line can then put this instability right.

However, the pulsations can also be caused by water overflowing from a flooded intermediate condenser.

➤ Check for limescale deposits in the jet ejector and check the cooling water pressure and tail pipes.

2. If a multi-stage steam jet vacuum ejector (e.g. designed for 10 mbar) is too large in terms of its suction volume, the booster can reach freezing point at 5 mbar and below at very low suction

load (if it is not heated). In this case, it will pulsate when alternating between freezing and thawing.

➤ Heat it. If a heating system is in place, inspect it.

3. The jet ejectors' characteristics demand that where there are two stages, the discharge pressure curve of the first stage and the suction pressure curve of the second stage must always overlap adequately. If processing loads change significantly and this is no longer the case, pulsations can occur.

➤ Check whether steam and gas have accumulated from the process. Inspect the boosters. Disconnect the process unit and carry out a performance check with the boosters at various loads.

Test rig for performance tests on steam jet ejectors



## Dismantling and internal inspection

If the fault cannot be found or located by checking any external or internal influences or by a gradual performance check, the unit needs to be dismantled step by step.

1. When inspecting the jet ejectors step by step, pay attention to the serial numbers, which are stamped on the front of the motive nozzles and on the rims of the diffusers' flanges. If the numbers are hidden due to paint or other reasons, verify and re-apply them.
  - > In the case of the venting unit (see figure on page 3), start with the atmospheric stage. Check the motive nozzle (see description on page 6).
2. The same applies to the diffusers.
3. Check that the gaskets in the connecting pipes sit properly and are in good condition. Misaligned gaskets reduce performance and can crack.
4. Now you need to inspect the intermediate condenser from the inside and the upstream stages until the fault is found.
5. Check the spray angle of the cooling water nozzles in the main mixing condenser (if there is one).
6. A guide to dismantling the jet ejectors and the cooling nozzles can be found in the operating instructions.
7. If there are boosters (in front of the main condenser), only check the motive nozzles and the heating (if available) for the time being.

> replace the nozzles.

As an emergency solution, re-boring may be carried out, however only after prior approval and a briefing by Körting project engineers.



# Measuring the suction pressure/vacuum

The suction pressure is measured on the suction nozzle or the head of the jet ejector. If everything's working properly, the guaranteed pressure should be shown. Taking into account any losses in the feed pipe (inlet, length), this suction pressure creates the vacuum in the vessel requiring evacuation (in the process).

## MEASURING LOCATION AND MEASUREMENT CONNECTION

The suction pressure is measured at an (existing) measurement point on the suction nozzle or the head of the jet ejector. If a new connection point is required, a hole should be drilled (10 mm diameter, perpendicular to the direction of flow, without burr) where there is a straight pipe with undisturbed flow.

The connection pipes (minimum diameter 10 mm, made of copper, thick-walled rubber or transparent plastic) should be laid so that they are as short as possible and don't sag.

To avoid condensate (evaporation, blocking the measurement pipe), the measurement lines must be ventilated regularly. Keep the pipes clean. Transparent pipes allow you to check the condition of the pipe at any time. Cold traps and chemical drying devices are not permitted. Handle connection points very carefully. Due to the relatively small measurement pipe, any leak would distort the measurement considerably. A shut-off device in the measurement pipe allows the measurement device to be connected to the vacuum without affecting the pressure that needs to be measured.

## PRESSURE GAUGES (FOR VACUUM)

Use a suitable absolute pressure gauge to measure the suction pressure. (Recommendations for suitable measuring devices are available from Körting project engineers on request).

Note the following points:

- The pressure transmitters must be calibrated before each measuring cycle (absolute zero and at least one point for the measuring range). If you don't have a calibration device, a plausibility check must be carried out at least (2 different measuring devices showing exactly the same value).
- The class of the measuring instruments must be observed. The error specified (usually related to the full scale value) must be converted for the current measuring point and should be  $\leq 1\%$ . Only lab measurement devices can normally meet this requirement. Standard measurement devices are usually too inaccurate in this case.
- The measurement range of the device must be matched to the pressure that needs to be measured, i.e. the pressure measured should not be  $\leq 10\%$  of the measuring range end value.
- Take any dependence on the measurement device's position into account (see measurement device's instructions).
- Measurement devices must not be exposed to excessively high temperatures – especially if the pressure is measured at points where high temperatures prevail. In the case of devices where the temperature is not fully compensated for, temperatures that are too high can lead to incorrect readings (see the measurement device's instructions).
- There must be no foreign bodies in the measurement devices. The weight of any droplets or solid particles on the measurement device's membrane will produce an incorrect result.

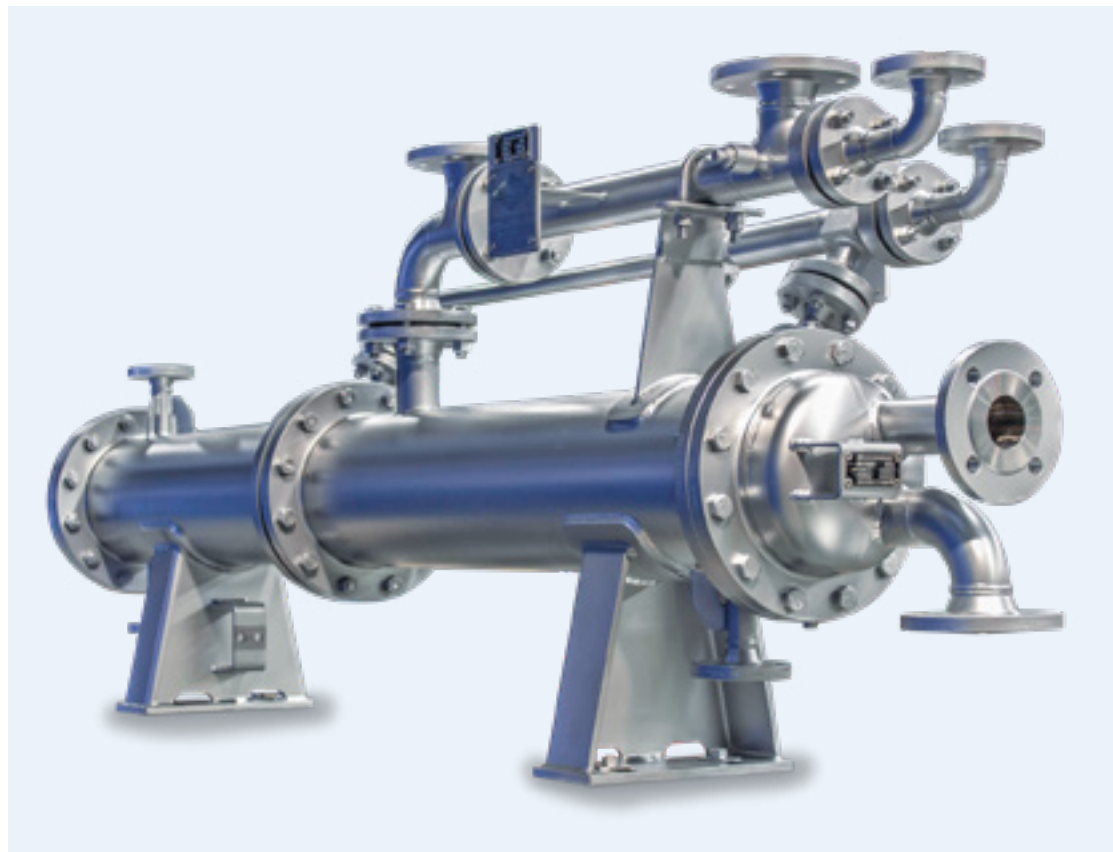

Two-stage steam jet vacuum system with surface condenser designed for chemical processes

## Measuring the suction flow

The actual suction flow can consist of various gases and vapours or of very diverse mixtures. Therefore, when carrying out a performance verification, it might prove impossible to reproduce the suction flow in many cases. Consequently, you will have to identify equivalent flows of air or steam to check the vacuum pump. To verify that a vacuum pump is operating correctly, it's often sufficient to carry out a test with an equivalent flow of atmospheric air (without taking the proportion of condensable steam into account). A multi-stage vacuum pump can be tested as a complete unit by following the procedure described above. However, each stage can also be tested separately. Then, the pressure ratios on the suction and discharge pressure side of each stage must be verified.

### MEASUREMENT METHODS

To determine the continuous suction flow of a gaseous medium, there are various methods such as pressure difference measurements at throttling points (orifice plates or nozzles) or direct measurements based on the displacement or float principle.

In the case of steam jet vacuum ejectors, measuring suction flow via supersonic flow through appropriately sized nozzles has proven to be a simple and sufficiently accurate method.

Atmospheric air or steam flows into the vacuum chamber of a steam jet vacuum ejector through one or more nozzles and the suction flow is determined only by the condition in front of the nozzle and by the narrowest nozzle hole. Therefore, in order to achieve the supersonic pressure drop, there must be pressure of  $\leq 500$  mbar in the suction chamber in front of the steam jet pump, e.g. with atmospheric air in front of the nozzle, which is almost always the case even with a single-stage steam jet vacuum ejector. If gases or vapours other than air and steam are to be extracted on site, these suction flows must first be converted into air or steam equivalents (kg/h), taking into account the actual temperatures (see diagram on the following page).

When measuring with atmospheric air, the influences of different barometer readings, humidity and temperature can be neglected maintaining a sufficient accuracy. As a result, specific air flow can be assigned to

a specific nozzle hole. In the case of steam, pressure, temperature and possibly humidity must also be taken into account.

**CORRECTION FACTOR FOR SUCTION FLOWS AS A FUNCTION OF MOLECULAR WEIGHT AND TEMPERATURE**

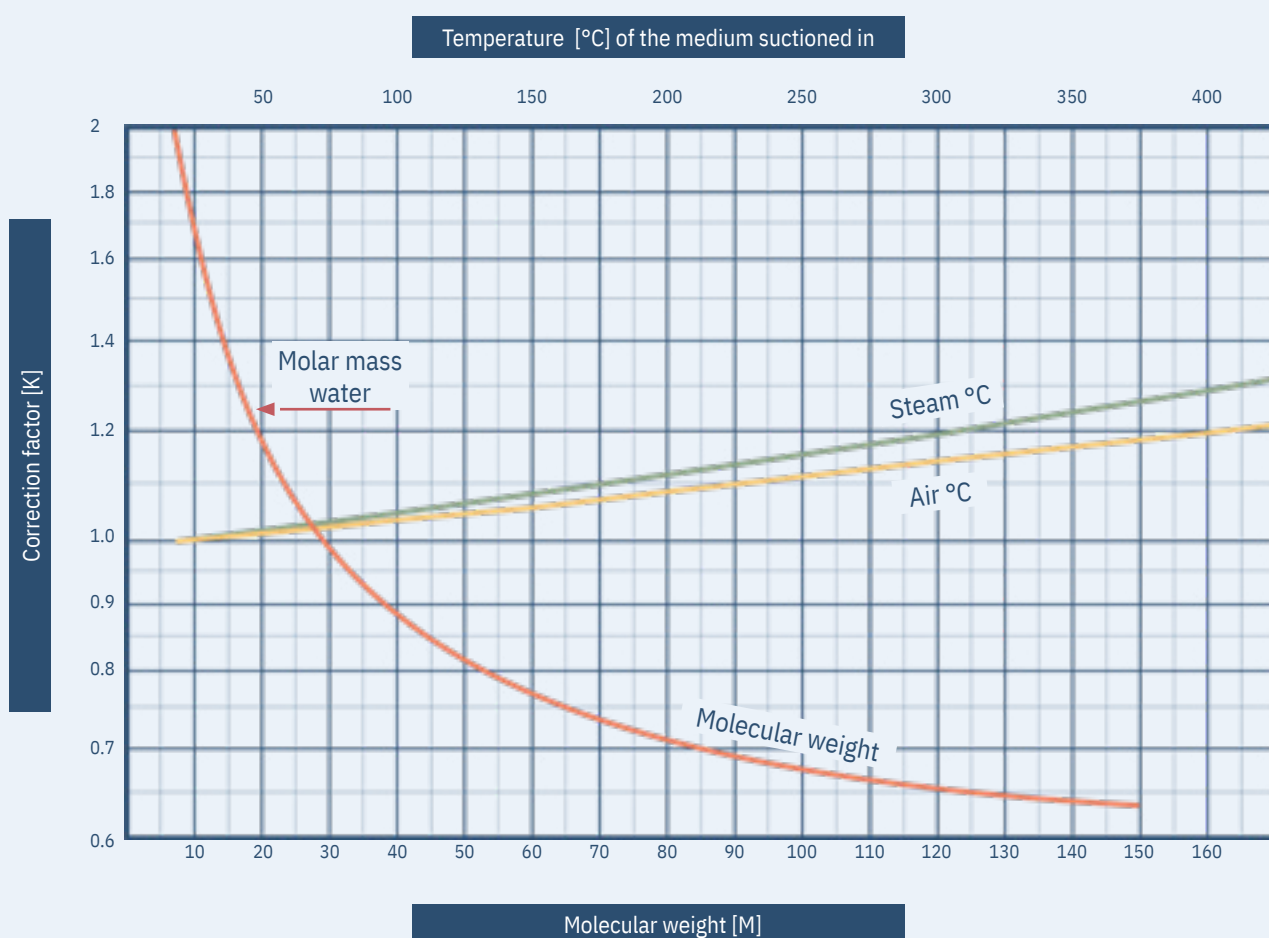

**Example 1**

5 kg gas (M = 80), 20°C  $\cong$  5 × 0.71 = 3.55 kg Air equivalent (M = 29), 20°C

**Example 2**

20 kg steam (M = 18), 20°C  $\cong$  20 × 1.25 = 25 kg Air equivalent (M = 29), 20°C

**Example 3**

100 kg steam 150°C  $\cong$  108 × 1.25 = 135 kg/h Air equivalent (M = 29), 20°C



You can also use our calculation tool.

## APPLICATION

If the actual suction flow can be used for a performance check, the vacuum system can be tested as one unit. If an equivalent suction flow has to be used, only jet ejectors connected directly in series can be tested as one unit. The equivalent suction flow only applies to jet ejectors. Conversion is based on fluid mechanics. In the case of condensers on the other hand, the mass flow's partial pressures govern the processes. Therefore, the condensers must not be present in any assembly that is being tested. Jet ejectors connected directly in series can also be tested individually. The maximum achievable discharge pressure should also be determined.

## MEASURING LOCATION AND MEASUREMENT CONNECTION

The required (equivalent) suction flow can be entered via several nozzles. It's advisable if the nozzles are not connected directly to the head of the jet ejector, but to a flow-steadying section inbetween (see below). Here, the suction flow can be distributed via the cross-section to ensure uniform flow in the ejector head. If the jet ejector cannot be separated from the system requiring evacuation, it might need to be rotated and provided with a nozzle adaptor.

### LAYOUT WHEN MEASURING STEAM FLOW AT A SUPERCRITICAL PRESSURE RATIO

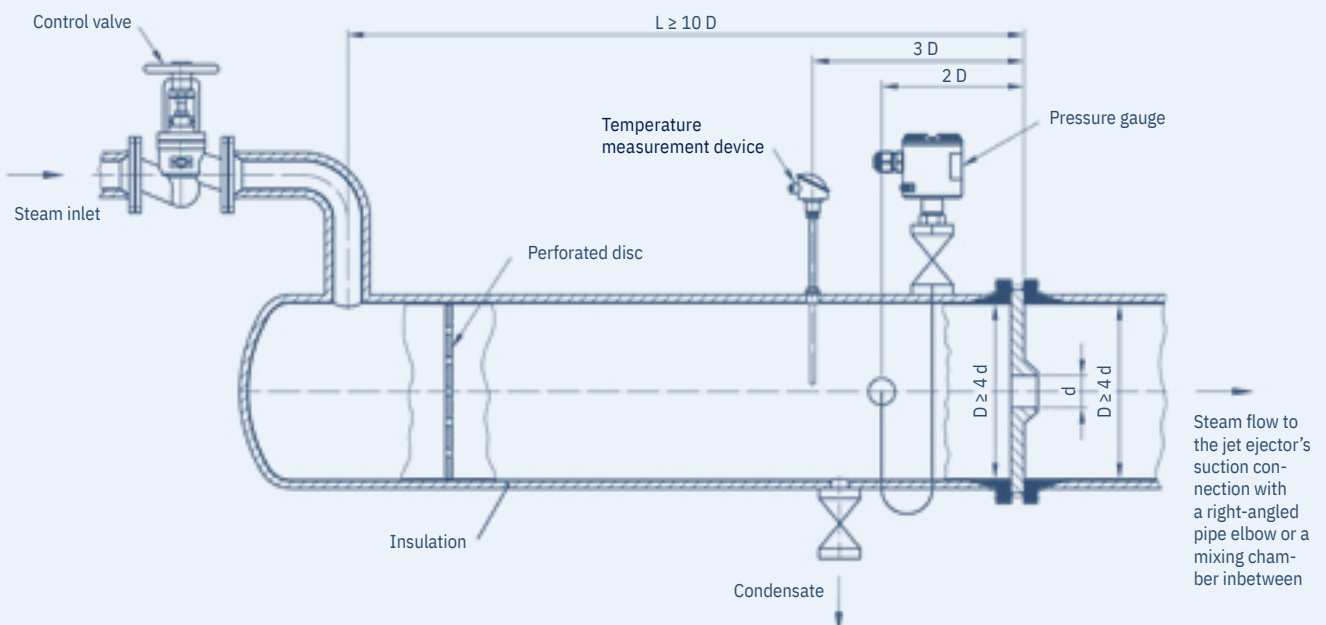

### LAYOUT WHEN MEASURING AIR FLOW WITH A HEI STANDARD NOZZLE AT A SUPERCRITICAL PRESSURE RATIO

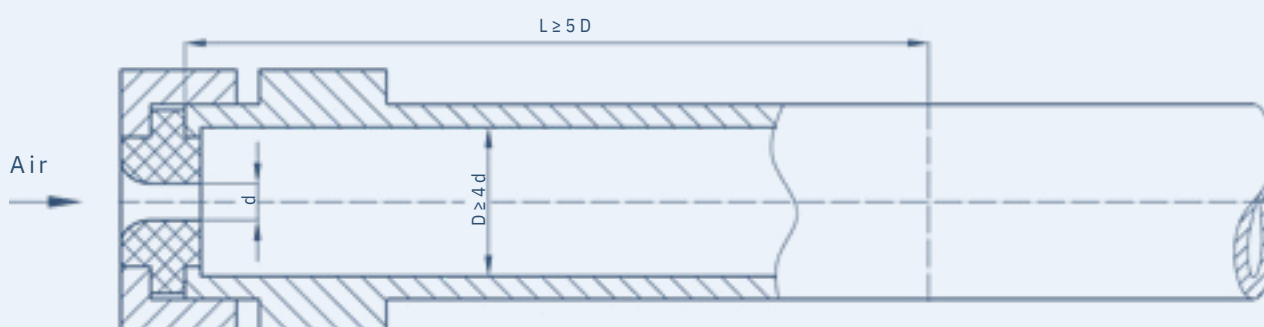

### MEASUREMENT DEVICES AND MEASUREMENT NOZZLES

If only atmospheric air nozzles are used, no further measuring devices are necessary. To reduce the measurement error, the air pressure can be determined in this case by an accurate barometer and the mass flow of the nozzles can be corrected. The same applies to the ambient temperature. If working with other gases and steam in non-atmospheric conditions upstream of the nozzle, the pressure and temperature must be measured there. The information on page 11 applies to pressure gauges.

HEI standard nozzles (HEI = HEAT EXCHANGE INSTITUTE, New York) are used for performance measurement (see figure on the right). Thanks to their standardised shape and surface quality, the nozzle loss factor can be clearly defined and reproduced. If manufactured properly, these nozzles can therefore be used in an uncalibrated state.



To determine the mass flow, the equations in DIN 28430 can be applied or you can use our calculation tool.

### MEASUREMENT RATIO OF THE HEI STANDARD NOZZLES

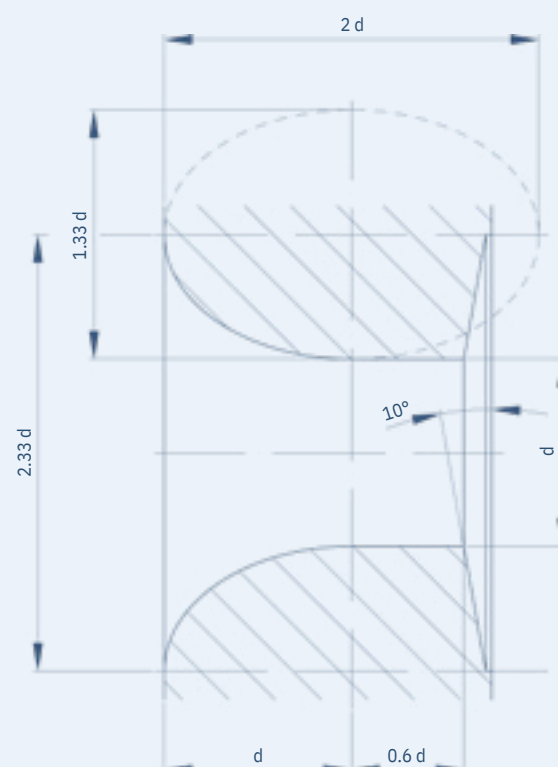

# Measuring the evacuation period

The evacuation period is the time in which the vacuum system has evacuated the volume concerned from ambient pressure to the ultimate vacuum as specified by the performance data.

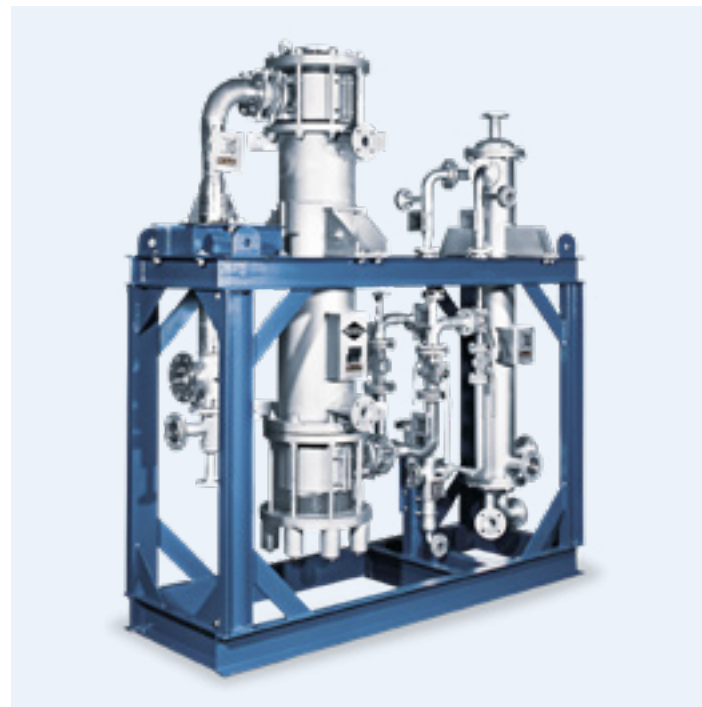

Two-stage steam jet vacuum system with surface condensers made of graphite and Hastelloy

# Measuring the motive flow

The motive flow is the steam flow through a steam jet vacuum ejector's motive nozzle. It must be dry (free of condensate), saturated or slightly overheated. As when establishing the suction flow, the flow through nozzles with a supercritical pressure drop is used as the measurement method.

The existing motive nozzle is used as the measurement nozzle in this case. The shape, which differs from the HEI nozzle, results in a smaller nozzle loss factor and therefore a lower steam flow than calculated based on the HEI standard.

Pressure and temperature must be measured directly in front of the motive nozzle. The diameter of the motive nozzle can either be measured, or you can refer to the operating instructions.



In the case of saturated motive steam, with known motive pressure and known motive nozzle diameter, the steam flow can be determined clearly with the aid of DIN 28430 or you can use our calculation tool.

# Measuring the cooling water flow

The cooling water flow is the mass flow of water entering a condenser.

The temperature increase - i.e. the inlet and outlet temperature of the cooling water - must be measured. If possible, the measurement should be made directly on the inlet and outlet nozzles. This minimises the impact from ambient factors. The thermometers can be fitted directly or with a thermowell. We recommend using electrical temperature sensors (e.g. PT100). It's important that the thermometers are calibrated regularly.

Some of the increases in temperature to be measured in the main condensers are just 3°C.

If the steam flow entering the condenser is known, the actual cooling water flow can be calculated from the heat balance. You can, of course, also establish the cooling water flow by using flowmeters.

You can also estimate the cooling water flow via the cooling water pump's characteristic curve, if the pressure increase in the pump is known.

# Performance check

A performance check on the steam jet ejector should always be carried out separately from the process unit. If there is no vacuum shut-off valve, the steam jet ejector on the first stage can be rotated along its longitudinal axis depending on the number of holes in the flange. The suction nozzle is fitted with a blind flange with a  $\frac{1}{2}$ " thread onto which the purchased or self-made test nozzle, or orifice plate, is screwed (see also page 15 as well as the operating instructions, in which an orifice plate diameter is specified that corresponds to an air volume according to the design, provided the orifice plate is sharp-edged).

Another connection on the blind flange must be provided for an absolute pressure gauge. The joints for measuring the intermediate pressures in each of the stages of multi-stage steam jet vacuum ejectors are located on the intermediate condensers.

Compare the values measured with the reference values in the operating instructions. Please note the values for later comparison.

# Zero load test (shut-off)

For a quick and easy test, it's often enough to check the shut-off behaviour. When the process unit is shut off and no air is added - i.e. at zero load - a steam jet vacuum ejector should achieve about half the pres-

sure it was designed for (e.g. about 5 mbar instead of 10 mbar pressure). If this figure is achieved, there can't be any major errors.

Three-stage steam jet vacuum ejector on the Körting performance rig



# Leakage test/ leak detection

Leaks can occur in the steam jet vacuum ejector and the process unit. You can test both items together or separately. However, detecting the leak is easier if the area concerned is as small as possible.

DIN EN 1779 describes suitable methods and how to use them. A distinction is made between methods that are carried out under vacuum or overpressure. Some of the vacuum testing methods are for example:

- Connecting a suitable detector that identifies a relevant testing gas that is sprayed onto the areas where leaks are suspected

or

- Leak detection via ultrasonic detectors

In terms of overpressure methods, bubble detection should be mentioned in particular. The areas with a suspected leak are brushed with a surfactant. The escaping air causes bubbles, which indicate where the leak is.

Ensure that the method is suitable. Test pressures must match the mechanical design of the unit. When using test gases, ensure that the unit is chemically resistant to these.

> **Please note: Pay attention to the material of the as well.**



# Check list and action if vacuum drops

Points to check	Action	Description in chapter	Page
<b>Measuring instruments</b>	Check display.	Sudden loss of vacuum	4
	Is recalibration required?	Measurement devices and measurement nozzles	15
<b>Touch</b>	Differences in temperature?	Suspected cause – cooling water	5
<b>Zero-load test (shut-off)</b>		Zero load test (shut-off)	17
<b>Motive steam</b>	Pressure drop?	Suspected cause – motive steam	6
	Wet steam?		
<b>Cooling water</b>	Too little or too much?	Suspected cause – cooling water	5
	Temperature?		
	Touch		
<b>Leak?</b>		Suspected cause – leaks	7
		Leakage test/leak detection	18
<b>Jet ejectors</b>	Check strainer	Suspected cause – motive steam Dismantling and internal inspection	6 10
	Motive nozzle clogged?		
	Motive nozzle eroded?		
	Diffusor eroded?		
<b>Final jet ejector</b>	Discharge pressure on exhaust pipe?	Suspected cause – motive steam	6
	Erosion?	Slow but steady loss of vacuum	8
	Zero-load test.	Fluctuating vacuum	9
	Not stable?	Zero load test (shut-off)	17
<b>Condenser</b>	Pressure, temperature?	Suspected cause – cooling water	5
	Touch	Slow but steady loss of vacuum	8
	Corrosion?		
<b>Mixing condenser</b>	Nozzle, tail pipe, hot well?		
<b>Surface condenser</b>	Condensate drainage? Fouling?		
<b>Booster</b>	Discharge pressure?	Action and recommended sequence when troubleshooting	3
	Ice, heating?	Suspected cause – motive steam	6
	Encrusted with deposits?		
	Nozzle erosion?	Fluctuating vacuum	9
<b>Process unit</b>	Leak?	Fluctuating vacuum	9
		Leakage test/leak detection	18
<b>Performance check</b>		Performance check	17
<b>Dismantle</b>		Dismantling and internal inspection	10



**Körting Hannover GmbH**  
Badenstedter Strasse 56  
30453 Hanover | Germany

+49 511 2129-0  
service@koerting.de

**K O E R T I N G . D E**